

**AVK** WATER SUPPLY



**WE DELIVER  
PURE  
QUALITY  
JUST LIKE YOU**

Expect... **AVK**





# LET'S ENSURE **SAFE AND CLEAN** **WATER FOR** **EVERYONE**

Reliability and purity are crucial when it comes to water supply. AVK products are renowned for superior quality thanks to our market leading expertise when it comes to rubber compounds. Due to own vulcanisation and coating facilities and worldwide approvals for drinking water we can ensure maximum safety and durability.

AVK has been in the valve business for more than 50 years. Today, we are offering solutions for numerous applications, not least valves, hydrants and accessories for water supply. Our wide range includes gate valves, butterfly valves, control valves, check valves, needle valves, air valves, service connection valves and hydrants as well as flange adaptors, couplings, fittings, tapping saddles, repair clamps, surface boxes and valve accessories.

Our quality assurance system is certified according to ISO 9001. Moreover, we are certified to ISO 14001, the international standard for environmental management, and to ISO 45001, the international occupational health and safety standard.

More than 4500 people in the AVK Group are doing their utmost to ensure that AVK remains one of the world's leading valve manufacturers for water, wastewater, gas, and fire protection applications.



# EXPECT LASTING INNOVATIONS

## Inhouse R&D

In our Development Department in Denmark, ideas and suggestions for new products are gathered, and existing products are updated continuously.

We use FEA (Finite Element Analysis) to optimise the strength and geometry of our components and CFD (Computational Fluid Dynamics) analyses to validate different product designs prior to creating physical prototypes.

This enables us to predict consequences in cases where it is impossible to create full scale tests on physical products.

We make our own test and production equipment, and in our flow lab, we conduct thorough prototype and life cycle tests prior to release for production. New product types are typically field tested in co-operation with end users before final launch.

## Quality certifications

AVK's quality management system is certified according to ISO 9001. Moreover, we are certified to ISO 14001, the international standard for environmental management, and ISO 45001, the international occupational health and safety standard.



# EXPECT US TO EXCEED MARKET STANDARDS

## Third party certification

Authorities such as DVGW (Germany), KIWA (Netherlands) and UL & FM (the US) offer certification of finished valves, and these are also recognised and accepted by other countries that do not have their own certification schemes.

By obtaining and maintaining the most widely accepted certification, we show our customers that AVK valves always meet the highest quality and safety standards.

## Expect... AVK

In our business there are five cornerstones that must be in place in order to meet customer expectations: Quality, reliability, innovation, sustainability and customer service.

But we need to go further than that. We go further to exceed our customers' needs and expectations.

"Expect... AVK" means that our customers should rightfully expect us to exceed market standards. "Expect... AVK" means that we relentlessly strive for increased customer benefits!

To ensure that we keep pushing the boundaries of what the market can expect, we have formulated promises that we will strive to deliver in all our markets:

- EXPECT** A LONG-TERM PARTNERSHIP
- EXPECT** QUALITY IN EVERY STEP
- EXPECT** LASTING INNOVATIONS
- EXPECT** TOTAL SAVINGS
- EXPECT** SOLUTIONS, NOT JUST PRODUCTS
- EXPECT** GLOBAL LEADERSHIP AND LOCAL COMMITMENT
- EXPECT** PROMPT RESPONSE
- EXPECT** IT TO BE EFFECTIVE AND EASY

See more on [www.avkvalves.eu](http://www.avkvalves.eu)



# AVK GATE VALVES RENOWNED FOR SUPERIOR QUALITY

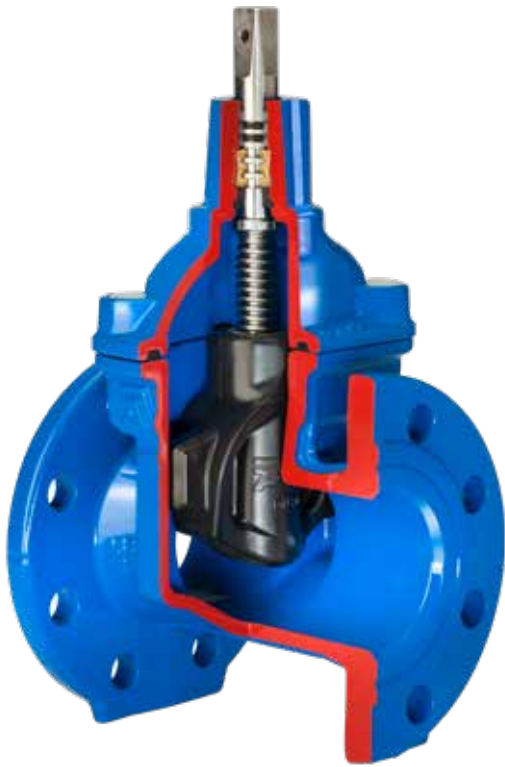

The wedge is the heart of a gate valve and the quality of the wedge rubber is crucial for the valve function and durability. AVK wedges are fully vulcanised with AVK's rubber compound offering outstanding characteristics.

The double bonding vulcanisation process ensures maximum adhesion of the rubber and prevents creeping corrosion.

#### **Fixed wedge nut prevents corrosion**

AVK's wedge nut design with a fixed, integral wedge nut outperforms the traditional loose wedge nut design as it prevents vibration and thus also corrosion and malfunction. It is made of dezincification resistant brass certified for use in contact with drinking water according to the stringent EU standards.

#### **Wedge shoes for smooth operation**

The fixed wedge nut and the vulcanised wedge shoes secure a smooth operation of the valve and low operating torques. The wedge shoes protect the rubber against wear which otherwise would arise from friction during operation.

#### **State-of-the-art rubber technology**

AVK GUMMI A/S develops and manufactures the rubber compound for wedges and gaskets using highly advanced technologies.

Data is collected throughout the entire manufacturing process which secures traceability of every single ingredient, compound and final component. AVK performs a number of tests to ensure that the compression set values, the adhesion and the tensile strength of the rubber meet the predefined requirements.

#### **Safe operation**

The large stem hole prevents stagnant water and accumulation of impurities. The large rubber volume in the sealing area combined with the excellent compression set provide optimum sealing.





**Efficient bonding is the key to durability**

The wedge core is immersed in two different baths to provide ultimate bonding between core and rubber. Even if a sharp object penetrates the rubber during closing of the valve, the bonding is so strong that there is no risk of creeping corrosion. As a result, we offer the best possible corrosion protection of the wedge.

**No contamination of drinking water**

The EPDM rubber recipes are composed with focus on minimising the formation of biofilm. The rubber will therefore not provide breeding ground for bacteria.

**High resistance**

The drinking water approved EPDM compounds are resistant to ozone and water treatment chemicals, and are of course taste, smell and colour neutral.

**Excellent ability to regain original shape**

AVK GUMMI A/S has a profound knowledge of a rubber's compression set, meaning its ability to regain original shape.

Even after many years of service where the wedge rubber has been compressed numerous times, the rubber will regain its original shape and ensure a tight sealing. Impurities will not affect the tightness of the valve, as the impurities will be absorbed in the rubber when the valve is in closed position and will be flushed away when the valve is reopened.



In closed position impurities are absorbed in the rubber



When reopened the rubber will regain its shape

# AVK GATE VALVES OFFER UNIQUE FEATURES

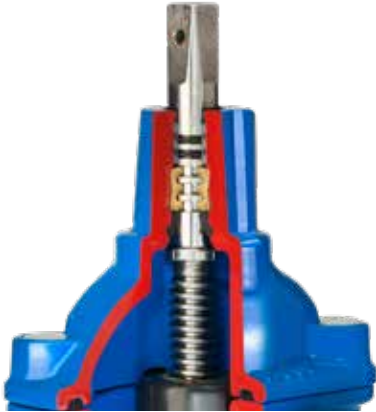

## Gate valves DN450-600

In DN450-600 the valves are designed with two roller bearings and a thrust collar of stainless steel to ensure low operating torques.



## Gate valves DN800-1000

Thrust washers and nylon bearings are used due to the higher axial forces.

### Wedge stop and rolled threads

The wedge stop provides a firm stop against the wedge nut when opening the valve. This prevents the wedge from compressing the stem seals and from damaging the coating inside the bonnet. Therefore, the wedge stop gives prolonged durability of the valve.

The stem threads are rolled in a cold pressing process which maintains the steel structure and therefore increases the strength of the stem. This method also ensures a smooth thread surface that gives low operating torques.

### Triple safety stem sealing

An NBR wiper ring protects against impurities from the outside. Tightness and low friction are provided by four NBR O-rings in a polyamide bearing, or optionally a replaceable brass stem nut, preventing galvanic corrosion. An EPDM manchette is the main seal to the flow.

The full circle thrust collar of high strength dezincification resistant brass provides fixation of the stem and low free running torques.

The stem is mounted from below, and the thrust collar expands inside the bonnet and fixes the stem, preventing it from being blown out.

### Three strong coatings

The standard corrosion protection is an internal and external fusion bonded epoxy coating in compliance with DIN 3476 part 1 and EN 14901, GSK approved. We control each batch of epoxy coated components to ensure a layer thickness of minimum 250 $\mu$ , a pore-free surface, high impact resistance and adequate curing. In addition to our own tests, the independent GSK authorities control the adhesion and cathodic disbonding of the epoxy coating according to their guidelines.

Furthermore, we offer gate valves with a highly wear-resistant internal enamel lining offering excellent protection against creeping corrosion.

We also offer an external polyurethane (PUR) coating which gives outstanding protection of the valve against galvanic corrosion, shielding the valve completely from its surroundings. In addition, it eliminates any risk that electrical currents will penetrate the valve and gives additional protection when installed in aggressive soils. The polyurethane coating is quality tested according to EN10290 type 2, class B.





### Tight assembly of valve body and bonnet

An EPDM bonnet gasket is fixed in a recess in the bonnet to prevent blow-out. The stainless steel bonnet bolts are encircled by the bonnet gasket, embedded in the casting to ensure that no threads are exposed to the surroundings, and finally sealed with hot melt to prevent corrosion.

### Strong PE end connection

A fully welded PE pipe system offers a lot of benefits such as reduced risk of leakage, ease of installation and a high durability. With AVK's comprehensive range of gate valves with PE pipe ends you can design a fully welded PE pipe system up to 630 mm.

A piece of standard PE pipe is pressed directly onto the grooved valve end. The grooves combined with a sleeve around the valve/pipe connection ensure that the PE pipe material is firmly secured and that the connection remains tight and tensile during the entire service life of the pipeline. The connection is sealed with a shrink hose to provide corrosion protection.

### Pressure test

Every single valve is pressure tested according to EN 1074-1 and 2 /EN 12266 before leaving the factory.



### Feature summary

- Fixed, integral wedge nut prevents corrosion caused by vibration
- Wedge and body guide rails ensure stable operation
- AVK's wedge rubber has an excellent ability to regain its shape
- AVK's wedge rubber features an excellent bonding, minimum formation of biofilm and a high resistance to water treatment chemicals
- Wedge shoes protect the rubber against wear
- Large stem hole in the wedge prevents stagnant water
- Rolled threads increase the stem's strength
- Anti-blowout stem design
- Wedge stop protects seals and coating
- Triple safety stem sealing
- Thrust collar provides fixation of the stem and low free running torques
- Bonnet gasket is fixed in recess and encircles bonnet bolts to prevent blow-out
- Countersunk bonnet bolts sealed with hot melt to protect against corrosion
- Full bore ensures low head loss and enables use of pipe cleaning devices
- Low operating torques ensure easy operation
- Fusion bonded epoxy coating in compliance with DIN 3476 part 1 and EN 14901, GSK approved, optionally internal enamel and external PUR coating

# AVK DOUBLE ECCENTRIC BUTTERFLY VALVES THE SAFE CHOICE



AVK offers double eccentric butterfly valves in DN150-2800 designed with durability in focus. The tilted and firmly secured disc, the optimised seal design and the corrosion protected shaft end zones are features that exceed the market standards.

#### **Longer service life due to tilted disc**

The tension on the disc is released after a few degrees of opening which minimises wear of the disc seal. Furthermore, the design minimises the compression of the sealing which ensures low operating torques.

#### **Safe disc and shaft connection**

The disc and shaft are connected by means of a key and a keyway. The key is secured with two set screws to prevent fluttering caused by flow velocity and necessary play in the key and keyway connection. In the large dimensions the disc is secured with two stainless steel drive dowels, with key and keyway as back-up.

#### **Two seat designs**

The integral seat design has a machined and epoxy coated ductile iron seat integrated in the body. The stainless steel seat design has a replaceable seat ring of stainless steel sealed with an O-ring to avoid leakages under the seat ring.

#### **Disc seal optimised for high performance**

The disc seal is shaped to secure fixation in correct position providing a very reliable function. The excellent rubber quality makes it possible to reduce the amount of rubber which ensures low closing torques. The EPDM sealing is approved by DVGW, KIWA and WRAS.

The stainless steel retainer ring keeps the disc seal in place. It is fixed with stainless steel bolts coated with precoat 80 to prevent loosening. The threaded bolt holes in the disc are corrosion protected with O-rings around the bolt heads.





### Shaft design features

The shaft sealing is replaceable under pressure to enable easy maintenance. Sealings of EPDM secure tightness from inside and out, and NBR sealings protect against impurities and fluids from outside.

The butterfly valves are prepared for a locking device which makes it possible to lock the disc in open/closed position if gearbox replacement becomes necessary.

The low friction PTFE bearings ensure low operating torques and the protected shaft ends secure durability since there are no uncoated ductile iron surfaces exposed to the media.

### Bi-directional and slim

The valves are bi-directional even though valves from DN700 and up are marked with an arrow indicating the preferred flow direction. The weight is minimised to make handling easier, and to put less strain on the environment.

### Product approvals

The butterfly valves are approved by:

- DVGW up to DN1200
- KIWA up to DN600
- WRAS in DN700-1200

For larger dimensions all components are approved.

### Actuation of your choice

AVK can offer any type of actuation. Our standard options are IP67 gearboxes with handwheel for above ground installation, IP68 gearboxes for buried service, and ISO-input gearboxes for mounting of electrical actuators. Furthermore, we offer extension stems, adaptors and handwheels.

Up to DN600 the shaft ends are protected with stainless steel plates with gaskets.

After mounting and successful pressure test, an extra layer of epoxy coating seals the steel plates. In larger dimensions the shaft ends are fully encapsulated in the disc and fixed to the disc with dowels.



# AVK CENTRIC BUTTERFLY VALVES FIXED OR LOOSE LINER



AVK offers the widest range of butterfly valves at the market. The fixed liner butterfly valves from AVK are among the very few of its kind and offer outstanding advantages. Furthermore, we offer a wide range of loose liner butterfly valves.

## Unique fixed liner design

An outstanding seating concept is the heart of the valve. The rubber is injection moulded directly on the valve body forming a permanent bond with an optimal rubber shore hardness. Consequently, there is no risk of deformation or dislocation of the liner and the valves are therefore suitable even under vacuum conditions.

The disc has a profiled sealing edge which requires minimal deformation of the liner to achieve a tight sealing. This gives less wear of the liner and low operating torques.

## Feature summary

- Fixed liner with no risk of deformation or dislocation, thus suitable under vacuum conditions
- AVK rubber liner with excellent ability to regain shape after compression
- Disc with profiled sealing edge gives less wear of liner
- Low operating torques due to fixed liner, profiled disc and shaft bearings
- Streamlined disc prevents turbulence, pressure drops and valve vibration
- Available as wafer, semilug, full lug, double flanged short and double flanged long in DN40-2000 with any type of actuation

## No turbulence or pressure drops

The streamlined disc gives low flow resistance when the valve is open. Therefore, the valves will not cause any turbulence, pressure drops or valve vibration, and will reduce energy costs for the user.



## Profiled disc and unique AVK rubber ensure exceptional durability

The unique AVK rubber compound has an excellent ability to regain shape after compression, and this ability combined with the profiled disc secure tightness even after thousands of operation cycles.



### Wide range with loose liner

AVK's range of loose liner butterfly valves comprises wafer, lug and U-section butterfly valves in DN25-1600 with any type of actuation and with a wide selection of disc and liner materials.

The replaceable liner of drinking water approved EPDM has a very robust construction. Its convex form and integrated lip sealings in the shaft passage ensure a tight connection with the shaft. Moreover, the special shape ensures a unique grip to the body, preventing any relative liner displacement during operation. The integrated gasket faces enable easy installation between flanges.



### Feature summary

- Stainless steel shaft with anti-blowout design and position indication
- Square driven disc mechanism with effective power transmission
- Disc of acid-resistant stainless steel with streamlined shape for optimum flow characteristics and polished edges for minimum wear of the liner
- Replaceable EPDM liner with a unique design
- Ductile iron body with extended neck for insulation and 200my fusion bonded epoxy coating

# AVK SWING CHECK VALVES ENSURE OPTIMUM PUMP PERFORMANCE



## Unique design

By unscrewing a few bolts the bonnet assembly including hinge and disc can be removed from the body. The hinge is tightened around the shaft with bolts to eliminate play and thus ensure durability.



AVK offers a wide range of swing check valves featuring full bore and low head loss resulting in maximum utilisation of the pump capacity. The swing check valves can be installed in both horizontal and vertical positions and are easy to maintain.

AVK swing check valves are available in DN50-600 and feature full bore and low head loss as well as easy access to maintenance and great durability.

## Lever and weight

Swing check valves with lever and weight are appropriate for installations with an increased risk of water hammer at standard velocities.

The solution enables visual check and valves in small dimensions offer the possibility of priming by moving the lever manually. The weight is adjustable on the lever to achieve a soft closing against the seat as well as an optimum closing speed to prevent water hammer.

A guard covering the lever and weight eliminates the risk of injuries. Optionally with limit switches for remote monitoring.

Swing check valves with lever and external spring are suitable for high pressure, insufficient back pressure and high flow velocities.

## Feature summary

- Bonnet/disc design gives easy access to maintenance
- Disc with steel insert is fully vulcanized with EPDM rubber (up to DN300) ensuring optimum sealing ability
- Lip sealing on the disc ensures tightness
- Light-weight disc requires a minimum of force to open and close the valve
- The disc is mounted in a nylon bushing, which allows it to move slightly both horizontally and vertically to close completely tight also in case of minor impurities in the seat
- Hinge tightened around the shaft with bolts to eliminate play and thus ensure durability
- Full bore ensures low head loss
- Ductile iron fusion bonded epoxy coating in compliance with DIN 3476 part 1 and EN 14901
- Available prepared for limit switch



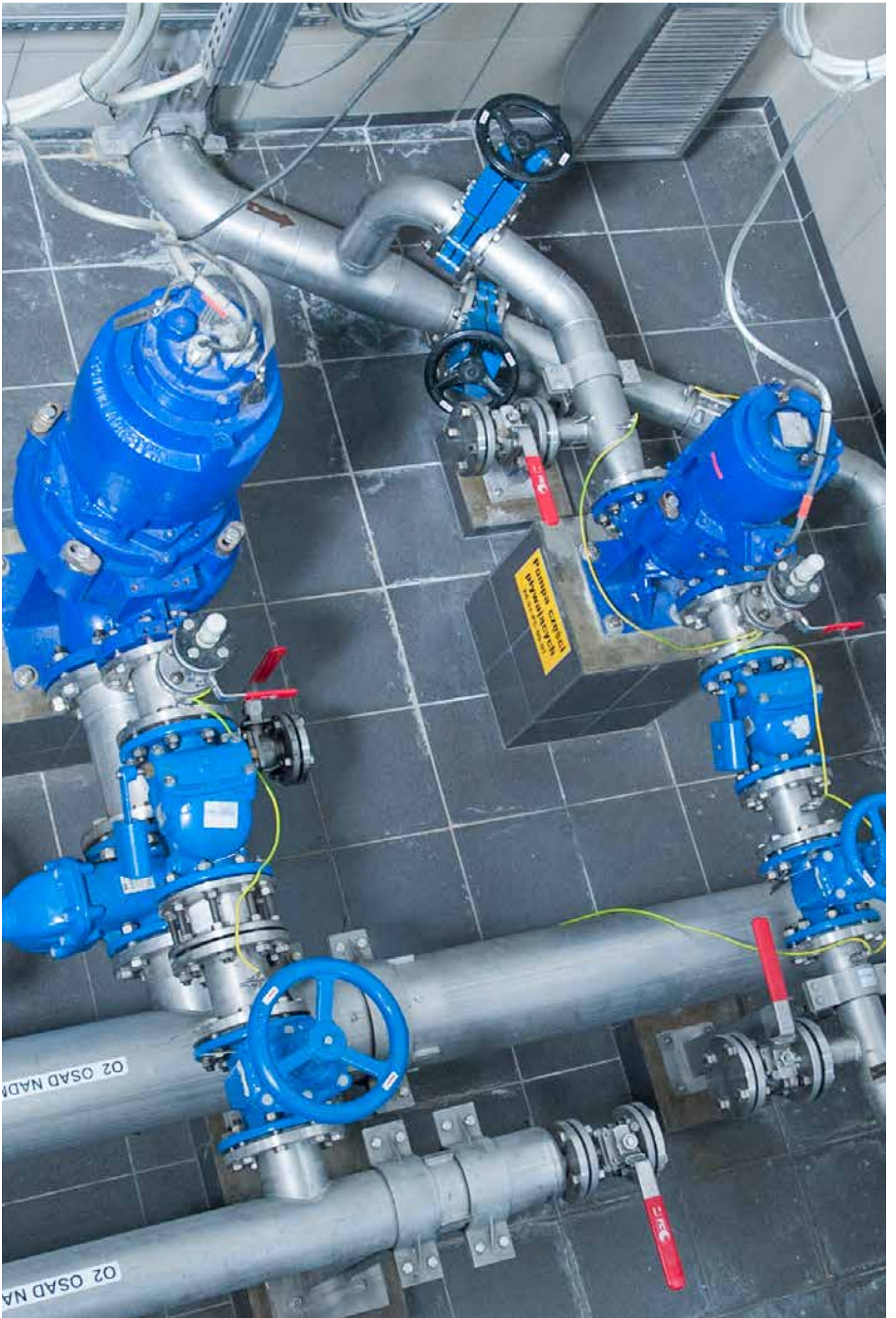

# AVK AIR VALVES FOR EFFECTIVE PIPELINE OPERATION



Top performance, minimum maintenance and high durability are the characteristics of AVK's wide range of automatic air valves, air and vacuum valves and combination air valves. The air valves are available in composite materials, which combine strength with extremely light weight and increased venting efficiency.

## Why use air valves?

Trapped air pockets in the piping system cause many problems:

- Increased corrosion
- Increased energy consumption and operation costs
- Failure or inaccuracies in flow metering
- Pressure loss or even complete flow stop delays in the filling of mains
- Increased risk of water hammer

Sudden movements of air pockets may result in a rapid change in flow velocity, leading to high pressure surges of a destructive nature.

## Automatic air valves

AVK automatic air valves series 701 are designed with a very soft and sensitive seal. It enables effective discharge of accumulated air from the system while under pressure. The automatic air release valve are lightweight and compact with a 12 mm<sup>2</sup> orifice enabling release of air at high flow rates not being exposed to obstruction by debris. All operating parts are made of specially selected corrosion-resistant materials.

## Air and vacuum valves

AVK air and vacuum valves are designed to discharge air during the filling of the system, and to admit air into the system during system drainage. The dynamic design allows for high velocity air discharge while preventing early closure. The special orifice seat design with a combination of bronze and EPDM rubber ensures long-term maintenance-free operation.







### Combination air valves

AVK combination air valves combine the function of automatic air release valves and air and vacuum valves. The automatic air release function releases accumulated air from the system while it is under pressure. The air and vacuum function discharges and admits large volumes of air during the filling or draining of pipelines.

The combination air valves are available in four main types:

- Compact design with rolling seat mechanism (701/4X)
- A design combining an automatic air valve with the air and vacuum valve (701/50 and 701/60)
- Underground air valve unit (701/84)
- Double-float design (851)

The underground air valve unit is designed to save manhole costs. It is suitable for frost protection and for installation under important crossings like roads and buildings where manholes would cause dangerous undermining of the ground.

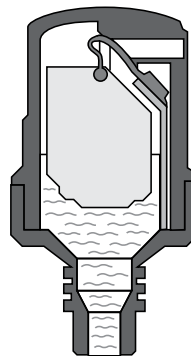

### Automatic air valve

For discharge of air liberated from fluid in water mains under pressure

- When air bubbles appear in the valve, the float will drop, allowing air to be released
- When the water rises again, the float will be lifted, and the valve will close

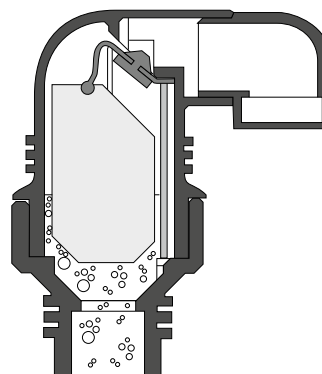

### Combination air valve

It combines the function of an automatic air valve with the following:

- When emptying the pipeline, the float will drop completely, allowing large volume air intake through the large orifice
- When refilling the pipeline the water flow will force the air out through the large orifice

# AVK CONTROL VALVES DIAPHRAGM OPERATED



## The safe choice with 10-year warranty

AVK diaphragm operated control valves are designed according to EN 1074-5 and to provide network stability, accurate regulation, easy maintenance and long durability.

AVK control valves are available in DN50-600, with reduced and with full bore. Control valves with reduced bore are appropriate for most applications, as the smaller bore often offers more accurate regulation. Control valves with full bore are recommended, if high Kv values are needed, e.g. in front of hydrants.

## High quality WRAS approved materials

The body and bonnet are made of ductile iron with fusion bonded GSK approved epoxy coating.

The diaphragm is manufactured by AVK GUMMI and made of drinking water approved EPDM rubber with polyamide reinforcement.

All non-coated internals are of stainless steel AISI 316 as standard and all materials are WRAS approved.

## Design features of the valve

- Large diaphragm design (1) secures fast reaction to changes in pressure. Its asymmetric axial position gives less stress near closed position.
- Lifted seat design (2) prevents damage inside the valve body caused by cavitation.
- Parabolic plug design (3) provides precise regulation and stability at low flow. Furthermore, it reduces noise and vibration. See below characteristics, illustrating the performance compared to a standard flat plug design.

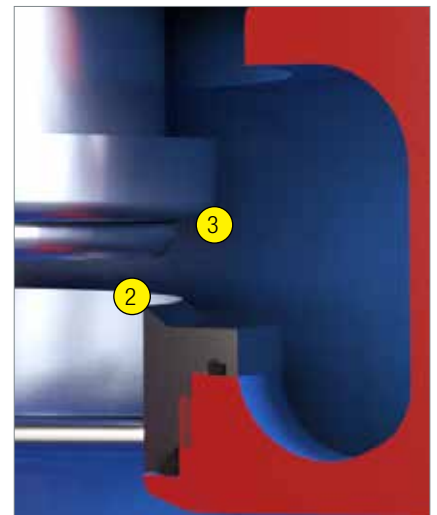
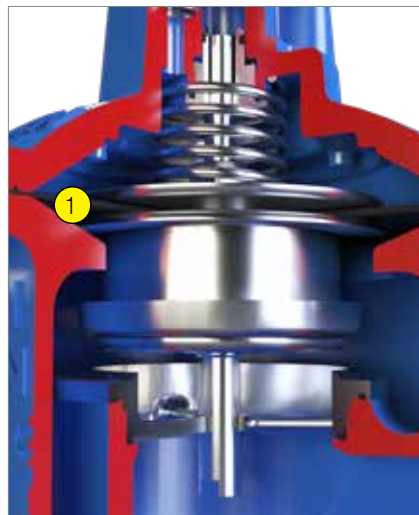
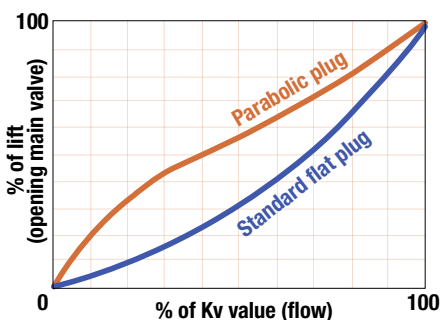

# PATENTED PILOT SYSTEM WITH UNIQUE FEATURES



Pressure reducing valve



Pressure sustaining/relief valve

## Modular pilot system

The modular design with interchangeable parts offers great flexibility as the pilot system is easily altered to fit other or multiple applications without replacing the valve. The pilot system consists of three main components:

- The distribution block (1) connects the pilot system to the main valve. As a unique feature, it offers adjustment of regulation speed for full control, easily adjusted using standard tooling, and giving full control e.g. in situations, where water hammer may occur.
- The filter (2) features high capacity and easy maintenance. When using the optional flush valve it also offers easy access to cleaning, while the valve is in operation.
- The hydraulic control block (3) can be set up for different applications. It features easy hand adjustment of the balanced pilot valve which is capable of very precise settings.

## Compact design

The external pipework takes up less space and is less vulnerable to damage during installation compared to many other control valves.

It is designed using components with standard threads offering easy sourcing of replacements as well as easy fitting using standard tools. All metal parts are of stainless steel AISI 316 as standard.

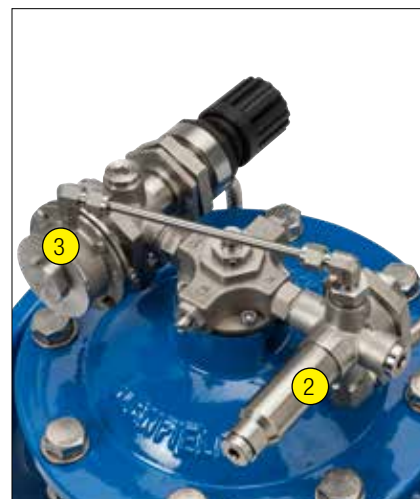

# AVK SERVICE CONNECTION VALVES OF DUCTILE IRON, BRASS AND POM



AVK service connection valves are long lasting and maintenance-free. The wedges are made of brass vulcanised with drinking water approved EPDM rubber according to the stringent EU regulations.

## Special wedge design

The wedge core is made of dezincification-resistant brass certified for use in contact with drinking water and vulcanised with drinking water approved EPDM rubber externally. The wedge is shaped with wedge guides, and a patented rubber profile ensures low closing torques.

The wedge rubber and vulcanisation is made at AVK GUMMI A/S with the same features and benefits as for mainline gate valves.

## POM valves

The bonnet, body and joints of POM (polyoxymethylene) are friction welded ensuring optimum strength. A built-in friction collar prevents overtorque of the valve.

## Brass valves

Our brass valves are made of hot forged dezincification-resistant brass certified for use in contact with drinking water and are designed with boltless connection between the body and bonnet. An NBR O-ring is countersunk and compressed when the valve bonnet is screwed onto the body thus ensuring a tight valve.

## Ductile iron valves

The design of our ductile iron service connection valves is the same as for the main-line gate valves except for the wedge design. The valves are as standard with internal and external fusion bonded epoxy coating in compliance with DIN 3476 part 1 and EN 14901, GSK approved.

## Summary of common features

- Wedge shaped with wedge guides ensures smooth operation
- AVK's wedge rubber has an excellent ability to regain its shape
- AVK's wedge rubber features an excellent bonding, minimum formation of biofilm and a high resistance to water treatment chemicals
- Rolled threads increase the stem's strength
- Thrust collar provides fixation of the stem and low free running torques
- Full bore ensures low head loss
- Low operating torques ensure easy operation

See separate brochure "AVK service connection system" for further details.



### Ductile valves

AVK offers a comprehensive range of service connection valves of ductile iron with internal threads, tensile socket ends, PE ends, screw couplings and PRK couplings as well as combinations with external thread.



### Brass valves

Our service connection valves of hot forged dezincification resistant brass are available with tensile brass screw couplings or PRK couplings and with AVK or T-type bonnet – all in DN25-50 for 32-63 mm PE pipes.



### POM valves

Our service connection valves of POM are available with PRK couplings, tensile socket ends, PE ends, and Pentomech™ couplings, as well as combinations with external thread. In addition, there are options with T-type bonnet.



### Wide range of tapping saddles

AVK offers a wide range of tapping saddles. A range that comprises tapping saddles for PE, PVC, ductile iron, cast iron, asbestos cement and steel pipes.

AVK tapping saddles offer easy and fast installation and reliable function and they are maintenance-free and designed to last.

See separate brochure "AVK service connection system" for further details.

# AVK SUPA LOCK™ THREADLESS CONNECTION SYSTEM



Connecting valves and fittings with a threaded connection can be time-consuming and often, it leaves part of the thread exposed to the medium and the external environment. Over time this will cause corrosion of the uncoated thread and may even result in a leakage. Supa Lock™ solves this problem.

#### Full corrosion protection

The patented Supa Lock™ system, provides a 100% corrosion free joint combined with fast and easy assembly with maximum flexibility. Thanks to its simple and ingenious design, Supa Lock™ offers long-term safety with optimum protection against corrosion and leaks and also protection against accidental disassembly of the joint when the pipeline is pressurised.

#### Valves, tapping saddles and fittings

The wide Supa Lock™ range consists of valves, tapping saddles and fittings in ductile iron with a heavy duty epoxy coating complying with the strict GSK requirements. Furthermore, ball valves and fittings in dezincification resistant brass complying with the EU directive for material used in drinking water installations are part of the range.

**Easy two-step assembly**  
After having lubricated the O-rings, the Supa Lock™ spigot end is pushed into the Supa Lock™ socket end, and the safety retainer is clicked on – and the assembly is done!





### Self-locking safety retainer

Supa Lock™ is designed as a tensile joint and withstands pressures up to PN16 x 1.5. The safety retainer is designed with an edge (1), which makes it self-locking whenever there is pressure in the pipeline. Therefore, no accidental disassembly can take place. The safety retainer has two finger knobs (2) for easy assembly and disassembly.



### No rotation of valves and connectors

Free rotation is restricted for the valves and the threaded connectors used for drilling machines to enable effective drilling. Small cast notches placed on the outer rim of the socket end and on the inner rim of the spigot end interlock and prevent rotation.

### Heavy duty O-rings provide extra safety

All Supa Lock™ joints are fitted with heavy duty Ø7 mm O-rings. They provide extra safety when taking into account that a minor permanent deformation of the O-rings is to be expected over the lifetime of the product. Also, when the joint is exposed to bending as a result of ground movements, the large O-rings provide maximum safety.

### 360° rotation of fittings

The design allows for a 360° rotation of the fittings, which is a unique feature only offered by the Supa Lock™ system. The free rotation of the joint allows the installer to direct the service pipe outlet in any direction from the main pipe, thus avoiding collision with other pipes or obstacles in the trench.

### Corrosion-free access points

For flanged connections in DN80-400, the wafer type spacer with Supa Lock™ socket connections offers a corrosion protected access point to the pipe. It can replace a tapping and in that way avoid weakening of the pipe.

Our range of socket and spigot fittings also serve as access points with no need for tapping the pipe.



# AVK EXTENSION SPINDLES IN A USER FRIENDLY DESIGN



Extension spindles are used for easy access to operation of valves installed below ground. AVK extension spindles are produced on fully automated state-of-the-art production equipment to ensure a uniform quality.

Our extension spindles are made of corrosion resistant materials and random samples are torque tested with up to 675 Nm to ensure long service life. The inner tube is press fit to the key and stem adaptor to safeguard the corrosion protection of the tube. The bottom cover protects the valve spindle from impurities and enables it to rotate freely.

The patented "Safe Click" design provides a secure and fast three-step mounting process on service connection valves. A quick-mounting clip secures the connection between the stem and the bottom adaptor and allows for mounting and demounting without use of tools.

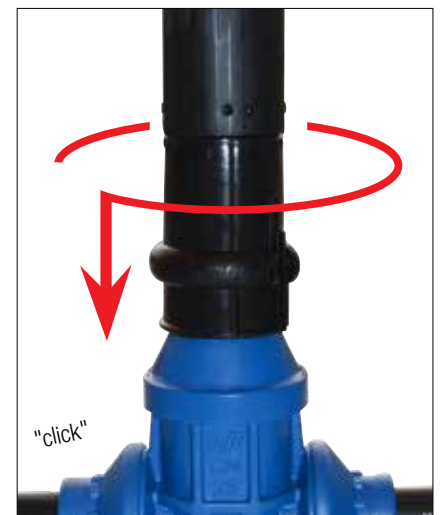





**Fixed length design features easy shortening**

Fixed length extension spindles are used when the distance between the valve and the ground surface is known so that adjustment of the length after installation is required to a limited extent or not at all.

The patented AVK design facilitates fast and easy shortening of the extension spindle. The complete adjustment of the length can be done merely by use of a hacksaw. The extension spindles are available with a pipe cover of 800-1000-1500-2000-3000 mm.

**Telescopic design facilitates on-site adjustments**

Telescopic extension spindles are used when the distance between the valve and the ground surface is unknown and when an adjustment of the extension spindle is required after installation.

The top adaptor is designed with a defrosting hole and with ears that can be fixed into AVK surface boxes and support tiles. A lock spring prevents the telescopic part from collapsing during installation, as it creates friction inside the inner tube.

The blue center sleeve protects against penetration of impurities between the two outer PE pipes.

**Telescopic extension spindles with break zone**

We also offer variants with break zone in the key adaptor which prevents damage of the valve in cases where a much too high torque is applied. In such cases the break nut of copper alloy is easily replaced, and the extension spindle can still be operated by means of a #20 socket wrench. Spare part sets are available.



Expanding bolt design facilitates easy height adjustment on fixed length extension spindles.



The top spanner and the inner tube are press fit on telescopic extension spindles.



# AVK SURFACE BOXES A FULL RANGE



AVK offers a very comprehensive range of surface boxes in various designs and material combinations.

#### **Cast iron surface boxes**

The ductile iron surface boxes are available in a floating design and a fixed/floating reversible design. The reversible surface box allows for deflection and internal fixation of telescopic extension spindles from both ends.

The fixed surface boxes of grey cast iron are height adjustable using ductile iron distance rings of a height of 10-50 mm.

#### **Floating surface boxes with great flexibility**

The internal fixation of telescopic extension spindles enables height adjustment after installation. The deflection ability secures optimal fit on sloped surfaces.

The large chamber provides easy access for mounting and demounting of the extension spindle, and the closed design protects the extension spindle against impurities.

- Square or round surface plate
- Body of polyamide PA-6 or ductile iron
- Surface plate and lid of ductile iron with black epoxy or blue epoxy coating.



### Synthetic surface boxes

Synthetic surface boxes are lightweight, ensuring safe and easy handling in compliance with Health and Safety Regulations.

They are maintenance and corrosion free giving easy access throughout the year with no need to clean or grease the seat to protect against corrosion or frost.

Furthermore, they are silent in traffic zones as the synthetic material absorbs noises, and they are 100% recyclable and heat resistant to max. 250°C.

### Designed for tough conditions

The housing is made of PA+ (polyamide with additives) making the surface box suitable for heavy duty application areas in all seasons and conditions.

The material has high impact resistance at low temperatures and is sufficiently heat resistant for safe installation in tarmac roads. The ribs in the housing ensure optimal fixation in the road foundation.

### Height adjustable surface boxes

AVK offers a wide range of DIN DVGW approved height adjustable surface boxes specifically designed for tarmac installation. They enable easy and precise installation thanks to flexible positioning of the top part.



Height adjustable surface boxes prevent costly correction after installation and save time and money when roads are renovated.

The variants with reinforced rim offer increased support of the top part making them even more robust and suitable for heavy duty areas.

### Fixed height surface boxes

Our Classic fixed height surface boxes are DIN DVGW approved and designed to withstand heavy traffic loads. Therefore, they are often used in medium and heavy duty areas.

Our Futura range is a lightweight and price competitive version and is often used in light to medium duty areas.

### Support tiles and top frames

Support tiles significantly increase the support required by surface boxes in weak soils. They also prevent telescopic extension spindles from being pushed back.

Top frames protect surface boxes in green zones and improve the visibility of the surface box. With a top frame, grass will not overgrow the surface box and combined with a support tile, easy access to valves installed below is guaranteed.



### Recognisable synthetic lids

Lids made of synthetic material are corrosion free, unattractive to thieves, more aesthetic and lightweight, and in compliance with Health and Safety Regulations.

To prevent the lid from being lifted by the suction of a passing vehicle, the reduced weight is compensated for with a locking clip around the bolt. Furthermore, AVK offers a solution that makes the surface box easily detectable by means of a ferromagnetic detector.



# AVK COUPLINGS AND FLANGE ADAPTORS

## UNIVERSAL AND DEDICATED



AVK offers a wide range of universal and dedicated couplings, flange adaptors and end caps designed for easy installation.

### Three Supa® ranges

AVK offers three great ranges:

- Supa® - universal and non-tensile
- Supa Plus™ - dedicated and tensile for PE/PVC
- Supa Maxi™ - universal and tensile

### Supa® - universal

- $\pm 4^\circ$  angular deflection
- Drinking water approved EPDM gasket with moulded ribs absorbs minor imperfections in the pipe
- Straight couplings, step couplings and flange adaptors in DN40-600

### Supa Plus™ - tensile for PE/PVC

- $\pm 3.5^\circ$  angular deflection
- Combined gasket of drinking water approved EPDM rubber with tensile grip segments
- The compression type gasket makes it easy to insert the pipe, even in large dimensions
- Straight couplings, flange adaptors, end caps and gate valves in DN40-300

For both types:

- External bolt design prevents corrosion between sleeve and bolts
- Anti-friction coated bolts and nuts

### Supa Maxi™ - universal and tensile

Supa Maxi™ is a complete range of large tolerance universal tensile couplings and adaptors according to EN 14525. The range comprises straight couplings and flange adaptors in DN50-600, end caps in DN50-400, step and transition couplings in DN50-300, and gate valves in DN80-300.

Supa Maxi™ sets a new standard with its unique features:

- Fully universal and tensile on all pipe materials, and even on oval pipes
- Patented SupaGrip™ sealing support system with flexible bracket
- PN16 in all dimensions (WP -0,9 to 16 bar)
- $\pm 4^\circ$  ( $8^\circ$ ) angular deflection on each side
- Permanent protection caps protect during handling and installation
- No re-tightening of bolts
- Lifting eye from DN100
- Fusion bonded epoxy coating in compliance with DIN 3476 part 1 and EN 14901, GSK approved
- Gasket of EPDM approved for drinking water
- Temperature range  $-20^\circ\text{C}$  to  $+70^\circ\text{C}$





**AVK combi-flanges**

The range comprises tensile combi-flanges for PE/PVC and ductile iron pipes in DN50-300, non-tensile for PVC and ductile iron pipes in DN50-600, and non-tensile for steel pipes in DN50-300.

- The design features flexible positioning and chamfering of the pipe
- Up to  $\pm 3.5^\circ$  deflection of the pipe is possible even in tensile executions
- The pipe will not move inwards during installation which secures a tight connection

**Dismantling joints**

AVK dismantling joints provide easy installation and disassembly of flanged pipework and equipment and compensate for axial displacement of the pipe during installation and dismantling. The range is available in DN50-2200 in PN10 and 16, and optionally PN25.

AVK's expansion joint is suitable for connecting fixed flanged ends of a pipeline, and for accommodating axial length variation of a pipeline. It can be used for all pipe materials.

**Fabricated couplings**

AVK's range of dedicated fabricated couplings comprises non-tensile straight couplings, step couplings and flange adaptors in DN350-2000. The range is suitable for ductile and grey cast iron, steel, uPVC and GRP pipes for water and wastewater applications up to 25 bar.

Our range of universal fabricated couplings comprises non-tensile straight couplings and flange adaptors in DN400-2000 made in carbon steel and feature a wide tolerance of 30 mm up to DN450 and 40 mm from DN500. Optionally the universal couplings and adaptors are available in stainless steel, up to PN40 and in customised design.

**Repico® couplings**

The Repico® range consists of stainless steel universal couplings in tensile and nontensile versions. Repico® offers a quick and simple connection solution for all pipes with possibility of angular deflection and easy handling due to the compact and light-weight design. The range is available from DN15 and up to DN2000, and with EPDM as well as NBR sealings.

See separate brochure "AVK couplings and adaptors" for further details.

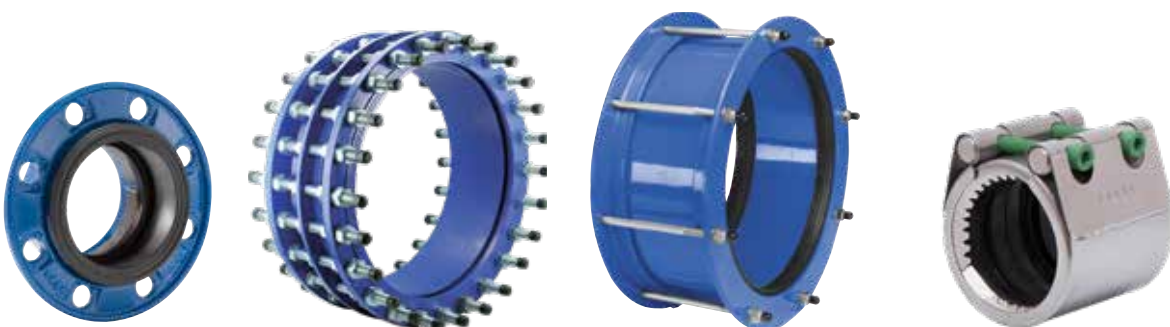

# AVK FIRE HYDRANTS ABOVE-GROUND AND UNDERGROUND



AVK offers a wide range of fire hydrants for above and underground installation and in a wealth of variants to meet our customers' needs.

## **Series 84 Multi hydrant**

The Multi hydrant is a modern, slim lined hydrant featuring our standard series 84 below ground barrel with all the components known from our existing range. The upper barrel is made of stainless steel for a modern look, and the hydrant head of ductile iron is epoxy coated and has an extra layer of UV resistant polyester coating.

The head can be machined for several outlet configurations according to customer specifications such as 2 x Storz B or C, 3rd Storz B or C and an optional Storz A on DN100. The Multi hydrant is available with or without traffic break-away design and with single shut-off or double shut-off.

## **Series 09 above-ground hydrants**

Our series 09 hydrants are 360 degrees rotatable and height adjustable for easy installation. In case of traffic knock down the PE pipe, connecting the upper barrel with the foot bend, will just bend and not break.

The hydrants are available of aluminium or ductile iron with manual or automatic drainage, and as top operated or gate valve operated. The automatic drainage hydrant is made in a flush-proof design by means of a membrane drainage valve designed to close when the hydrant is under pressure, and open when the hydrant is shut-off, allowing the water inside the barrel to be drained.

The epoxy coating and an additional topcoat of UV-resistant polyester give a high durability and a strong corrosion protection.





### Series 84 above-ground hydrants

Our series 84 hydrants are designed with a double shut-off system for safe sealing of the hydrant during maintenance. The flanges connecting the upper and the lower barrel are assembled with special titanium bushes which are the only spare parts to be replaced in case of an accidental traffic knock down.

The upper part is available in a nostalgic design, a modern stainless steel design and in an execution with a lockable cover protecting against unauthorized operation. The lower part is designed with a PUR vulcanised ductile iron disc and vertical seal like the series 35 hydrants.

Series 84 hydrants are as standard with automatic drainage, and optionally with manual drainage. Back-flow protection can be fitted to protect against contamination of the water through the hydrant. The internal enamel and the external GSK approved epoxy coating with an additional topcoat of UV-resistant polyester give a high durability and a strong corrosion protection.

### Series 29 underground hydrants

Our series 29/40 hydrants are based on AVK's renowned gate valve design with fully vulcanized wedge, fixed wedge nut and triple safety stem sealing. It is available with bayonet, Storz or NOR coupling.

Our series 29/50 variant is designed with a riser pipe of stainless steel and an AVK extension spindle.



### Free flow hydrant

The series 29/78 hydrant is designed without any parts obstructing the medium. The free flow gives a greatly enhanced flow-rate, it makes the hydrants insensitive to hard particles in the water, and offers easy insertion and retrieval of pipe inspection and maintenance equipment.

### Series 35 underground hydrants

Our series 35 hydrants seal vertically which gives a low closing torque and makes them easy to operate. The PUR vulcanised plug features a great compression set which ensures that the PUR will regain its shape after having been compressed. The automatic drainage ensures fully emptying of the hydrant after use. Series 35 is available with single shut-off or with double shut-off for easy maintenance, and optionally with internal enamel coating for extra corrosion protection.









# NEW LARGE-SCALE HOSPITAL PROJECT IN DENMARK

The New University Hospital in Odense, New OUH, will be one of the largest new hospitals in Denmark with its 250,000 m<sup>2</sup> under roof on the 780,000 m<sup>2</sup> site. The turnkey contract amounts to 953m euros.

It will become a hospital of the future and will be part of Campus Odense – a new town focusing on innovation and development. In addition to the New University Hospital, the new town will host the University of Southern Denmark, Science Park Odense and the new Cortex Park supporting knowledge sharing and networking between the business community, the university and the hospital. Generally, innovative thinking characterises the project, and for easy access, new roads are being established and a tramway is being constructed with two planned stops at the new hospital.

### Almost 300 AVK valves and hydrants

All valves and hydrants for the project have been supplied by AVK, mainly gate valves with PE ends for direct welding into the PE pipe system, and a lot of these are in DN300-400 to be used for cooling water. Furthermore, flanged gate valves and ball check valves will be used for the wastewater system, and 12 fire hydrants will be spread over the big site.

The new hospital is expected to open in 2022.

Product	DN	Psc	Application
Gate valves with PE ends series 36, including extension spindles and surface boxes	65-250	117	Water and wastewater
	300-400	76	Water and cooling
Fire hydrants series 84		12	Fire protection
Flanged gate valves series 06	80	56	Wastewater
Ball check valves series 53	80	28	Wastewater



# UNDERGROUND FIRE HYDRANTS AND GARDEN FOUNTAIN POSTS



**Series 29/40**  
Underground fire hydrant  
with bayonet coupling  
DN100  
PN16  
Ductile iron

- Options:
- 3" stortz oupling
  - 3" NOR coupling
  - 4" stortz coupling



**Series 29/50**  
Underground fire hydrant  
with bayonet coupling  
With AVK extension  
spindle and riser pipe in  
stainless steel  
DN100  
PN16  
Ductile iron



**Series 29/78**  
Underground fire hydrant  
Free flow  
Single shut-off  
DN80  
PN16  
750-1500 mm  
Ductile iron



**Series 35/31**  
Underground fire hydrant  
Single shut-off  
DN80  
PN16  
750-1500 mm  
Ductile iron

- Options:
- stainless steel seat



**Series 35/85**  
Underground fire hydrant  
Additional ball shut-off  
DN80  
PN16  
750-1500 mm  
Ductile iron  
Stainless steel seat



**Series 35/72**  
Underground fire hydrant  
DN100-125  
PN16  
1000-3500 mm  
Ductile iron

- Options:
- drilling according to GOST



**Series 30**  
Underground fire hydrant  
For mounting on AVK  
combi-cross  
DN100  
PN16  
Grey cast iron



**Series 80/60**  
Flexdrain  
Packing for underground  
hydrant  
DN80/100



**Series 78/7510**  
Fountain post  
"VICTORIA"  
Frost-proof  
DN40  
Grey cast iron

- Options:
- outlet for fire hose connection

# ABOVE-GROUND FIRE HYDRANTS



**Series 84/05**  
 Above-ground fire hydrant  
 Break-away design with  
 additional ball shut-off  
 Model P7  
 DN80/100  
 PN16  
 Ductile iron

- Options:
- lateral flange



**Series 84/72**  
 Above-ground fire hydrant  
 Break-away design with  
 additional ball shut-off  
 Model P7  
 DN80/100  
 PN16  
 Stainless steel

- Options:
- lateral flange



**Series 84/45**  
 Above-ground fire hydrant  
 Break-away design with  
 additional ball shut-off  
 Model P7  
 "NOSTALGIA"  
 DN80  
 PN16  
 Ductile iron

- Options:
- lateral flange
  - various coatings



**Series 84/91**  
 Above-ground fire hydrant  
 Breakable  
 single shut-off  
 Model N7  
 DN80/100  
 PN16  
 Stainless steel

- Options:
- non breakable
  - double shut-off
  - ductile iron



**Series 84/93**  
 Tunnel fire hydrant  
 Breakable  
 double shut-off  
 Model N7  
 DN80  
 PN16  
 Stainless steel



**Series 84/26**  
 Above-ground fire hydrant  
 Drop down pillar  
 Model P7, Type C  
 DN100  
 PN16  
 Ductile iron

- Options:
- lateral flange



**Series 09/30**  
 Above-ground fire hydrant  
 Screw down type B  
 DN80  
 PN10  
 Ductile iron

- Options:
- manual or automatic drainage
  - gate valve operated



**Series 09/50**  
 Above-ground fire hydrant  
 Type A  
 DN100  
 PN10  
 Aluminium

- Options:
- manual or automatic drainage

# FLANGED GATE VALVES FOR WATER



**Series 06/30**  
Flanged gate valve  
Face-to-face DIN F4  
DN40-1000  
PN10/16  
Ductile iron

- Options:
- internal enamel
  - duplex stem
  - replaceable stem sealing



**Series 06/52**  
Premium 100 gate valve  
Flanged  
Face-to-face DIN F4  
DN40-600  
Ductile iron  
External PUR coating



**Series 06/35**  
Flanged gate valve  
with position indicator  
Face-to-face DIN F4  
DN50-400  
PN10/16  
Ductile iron

- Options:
- face-to-face DIN F5



**Series 15/42**  
Flanged gate valve  
with ISO top flange for  
actuator  
Face-to-face DIN F4  
DN40-400  
PN10/16  
Ductile iron

- Options:
- face-to-face DIN F5



**Series 02/60**  
Flanged gate valve  
Face-to-face DIN F5  
DN40-500  
PN10/16  
Ductile iron

- Options:
- internal enamel
  - PN25
  - duplex stem
  - to GOST



**Series 02/75**  
Flanged gate valve  
Face-to-face DIN F5  
Replaceable stem sealing  
DN40-500  
PN10/16  
Ductile iron

- Options:
- PN25



**Series 02/52**  
Premium 100 gate valve  
Flanged  
Face-to-face DIN F5  
DN40-500  
Ductile iron  
External PUR coating



**Series 02/20**  
Flanged gate valve  
Face-to-face BS  
DN50-400  
PN10/16  
Ductile iron



**Series 55/30**  
Flanged gate valve  
DN450-500-600-800  
Face-to-face DIN F5  
PN10/16  
Ductile iron  
Resilient seated  
Replaceable stem sealing

- Options:
- DN80 By-pass



**Series 54**  
Flanged gate valve  
DN700-800-900  
Face-to-face BS  
PN10/16  
Ductile iron  
Metal seated

- Options:
- DN80 By-pass



**Series 18/70**  
Combi-cross  
with 4 outlets  
DN100-300  
PN10/16  
Ductile iron

- Options:
- with ball valve service outlets
  - with blind flange on DN100 centre outlet
  - with 3 outlets
  - DN80 center outlet



**Series 18/01**  
Combi-cross  
flexible design  
DN100-400  
PN10/16  
Ductile iron

- Options:
- with ball valve service outlets
  - with blind flange on centre outlet
  - duplex stem

# GATE VALVES WITH PE-ENDS, SPIGOT, COUPLINGS AND SOCKET ENDS FOR WATER



**Series 36/80**  
Gate valve with PE ends  
DN65-500

Od75-630 mm  
Ductile iron

- Options:
- SafeTech ends
  - duplex stem



**Series 36/52**  
Premium 100 gate valve with PE ends  
DN65-400

Od75-400 mm  
Ductile iron  
External PUR coating

- Options:
- Black/blue pipe ends up to 630 mm

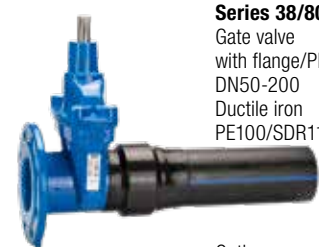

**Series 38/80**  
Gate valve with flange/PE end  
DN50-200  
Ductile iron  
PE100/SDR11

- Options:
- PE100/SDR17



**Series 638**  
Gate valve with Supa Maxi™/PE end  
DN80-300

Ductile iron  
PE100/SDR11

- Options:
- PE100/SDR17



**Series 636**  
Supa Maxi™ gate valve  
Universal and tensile coupling ends for all pipes  
DN80-300  
PN16  
Ductile iron



**Series 01/70**  
Supa Plus™ gate valve with tensile coupling ends for PE and uPVC pipes  
DN40-300  
PN16  
Ductile iron

- Options:
- duplex stem



**Series 12/51**  
Gate valve with flange/spigot end for cast iron pipes  
DN50-300  
PN10/16  
Ductile iron



**Series 32/40**  
Gate valve with long spigot ends for cast iron pipes  
DN80-300  
PN16  
Ductile iron

- Options:
- short spigot ends for D.I. pipes or AC pipes



**Series 06/38**  
Gate valve with grooved ends for cast iron pipes  
DN50-300  
PN16  
Ductile iron



**Series 01/80**  
Gate valve with "Euro" socket ends for uPVC-pipes  
DN40-400  
PN16  
Ductile iron

- Options:
- duplex stem



**Series 33/00**  
Gate valve with socket ends for cast iron pipes  
DN80-300  
PN16  
Ductile iron  
With internal enamel

- Options:
- internal epoxy



**Series 33/50**  
Gate valve with BLS® socket end/ BLS® spigot end for cast iron pipes  
DN80-300  
PN16  
Ductile iron

# DOUBLE ECCENTRIC AND CENTRIC BUTTERFLY VALVES



## Series 756/100

Butterfly valve  
Double eccentric  
Double flanged  
Integral seat  
IP 67 gearbox  
DN150-2800  
PN10/16  
Ductile iron

Options:

- stainless steel seat
- PN25 in DN150-1200
- internal enamel



## Series 756/106

Butterfly valve  
Double eccentric  
Double flanged  
Integral seat  
IP 68 gearbox  
DN150-2800  
PN10/16  
Ductile iron

Options:

- stainless steel seat
- PN25 in DN150-1200
- internal enamel



## Series 756/102

Butterfly valve  
Double eccentric  
Double flanged  
Stainless steel seat  
ISO input gearbox  
DN150-2800  
PN10/16  
Ductile iron

Options:

- integral seat
- PN25 in DN150-1200



## Series 75/10

Butterfly valve  
Centric with fixed liner  
Wafer type  
DN40-1400  
PN10/16  
Ductile iron

Options:

- various actuators



## Series 75/31

Butterfly valve  
Centric with fixed liner  
Semi-lug type  
DN50-200  
PN10/16  
Ductile iron

Options:

- various actuators



## Series 75/41

Butterfly valve  
Centric with fixed liner  
Full lug type  
DN50-1200  
PN10/16  
Ductile iron

Options:

- various actuators



## Series 75/20

Butterfly valve  
Centric with fixed liner  
Double flanged short  
DN50-2000  
PN10/16  
Ductile iron

Options:

- various actuators



## Series 75/21

Butterfly valve  
Centric with fixed liner  
Double flanged long  
DN50-1500  
PN10/16  
Ductile iron

Options:

- various actuators



## Series 820/00

Butterfly valve  
Centric with loose liner  
Wafer type  
DN25-1000  
PN10/16  
Ductile iron

Options:

- various actuators



## Series 820/10

Butterfly valve  
Centric with loose liner  
Lug type  
DN25-600  
PN10/16  
Ductile iron

Options:

- various actuators



## Series 820/20

Butterfly valve  
Centric with loose liner  
U-section type  
DN150-1600  
PN10/16  
Ductile iron

Options:

- various actuators



## Series 813/80

Butterfly valve  
Centric with loose liner  
Double flanged short  
DN350-600  
PN10/16  
Ductile iron

# CONTROL VALVES, NEEDLE VALVES AND CHECK VALVES



**Series 859**  
Control valve  
Pressure reducing  
DN50-600  
PN10/16  
Ductile iron/AISI 316



**Series 859**  
Control valve  
Pressure sustaining  
DN50-600  
PN10/16  
Ductile iron/AISI 316



**Series 859**  
Control valve  
Constant flow  
DN50-600  
PN10/16  
Ductile iron/AISI316



**Series 872**  
Needle valve  
DN 80-1600  
PN 10/16/25/40  
Stainless steel DN80-150  
Ductile iron from DN200

Options:

- various actuators and accessories
- up to PN100 and DN2000



**Series 41/61**  
Swing check valve  
Resilient seated  
Closed bushings  
DN50-300  
PN10/16  
Ductile iron



**Series 41/60**  
Swing check valve  
Resilient seated  
Free shaft  
DN50-300  
PN10/16  
Ductile iron

Options:

- lever and weight
- lever and spring
- prepared for limit switch



**Series 41/36**  
Swing check valve  
Metal seated  
Closed bushings  
DN350-600  
PN10/16  
Ductile iron

Options:

- free shaft



**Series 41/23**  
Lever and weight kit  
for swing check valve  
DN50-300  
Ductile iron



**Series 41/32**  
Spring kit  
for swing check valve  
DN50-300



**Series 41/1**  
Guard kit  
for swing check valve  
DN80-300



**Series 874**  
Tilting disc check valve  
With lever and weight  
DN150-1600  
PN10/16  
Ductile iron

Options:

- hydraulic damper



**Series 875**  
Slanted seat check valve  
DN200-1000  
PN10/16  
Ductile iron

# AIR VALVES AND FLOAT VALVES



**Series 701/10**  
Automatic air valve  
Threaded BSP 3/4" or 1"  
DN20-25  
PN16  
Reinforced polyamide

- Options:  
• brass base



**Series 701/20**  
Automatic air valve  
Threaded BSP 1/2", 3/4",  
or 1"  
DN20-32  
PN16  
Ductile iron



**Series 701/30**  
Air & vacuum valve  
Inlet flange  
DN50-300  
PN16  
Ductile iron



**Series 701/40**  
Combination air valve  
DN20, 25 and 50  
Threaded BSP 3/4", 1"  
or 2"  
PN16  
Reinforced polyamide



**Series 701/46**  
Combination air valve  
High flow  
Threaded BSP 2"/DN50-  
150 inlet flange  
PN16  
Ductile iron



**Series 701/50**  
Combination air valve  
Inlet flange  
DN50-300  
PN16  
Grey cast iron/  
Reinforced polyamide



**Series 701/60**  
Combination air valve  
Inlet flange  
DN50-300  
PN16  
Ductile iron



**Series 701/84**  
Underground air valve  
installation system  
DN50-100  
PN16  
Air valve box of PVC



**Series 851/41**  
Combination air valve  
DN50-200  
ABS float  
  
Options:  
• stainless steel float

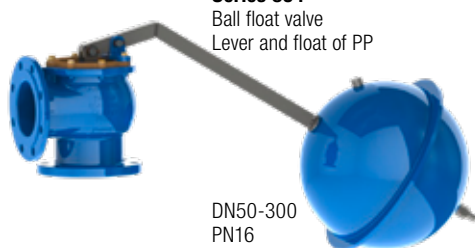

**Series 854**  
Ball float valve  
Lever and float of PP

DN50-300  
PN16  
Ductile iron

- Options:  
• lever and float of  
stainless steel



# SUPA LOCK™ THREADLESS CONNECTION SYSTEM



**Series 103/00**  
Service connection valve with Supa Lock™ spigot/socket end  
DN32  
PN16  
Ductile iron

- Options:
- Supa Lock™ spigot end/PRK coupling
  - duplex stem



**Series 103/31**  
Angle service connection valve with Supa Lock™ spigot/push-in socket end  
DN32  
PN16  
Ductile iron

- Options:
- Supa Lock™ spigot/socket end
  - duplex stem



**Series 343/81**  
Ball valve with Supa Lock™ spigot end/BSP thread  
1" - 1½"  
DN32, PN16  
Brass

- Options:
- Supa Lock™ spigot end/PRK coupling
  - Supa Lock™ spigot end/screw coupling
  - with T-type bonnet



**Series 100/14**  
Tapping saddle for iron/steel pipes  
Ø 60-223 mm  
DN32  
Ductile iron

- Options:
- for PE/PVC pipes



**Series 100/85**  
Tapping saddle with blade shut-off for iron/steel pipes  
Ø 50-360 mm  
DN32  
Ductile iron/stainless steel

- Options:
- for PE/PVC pipes



**Series 107/74**  
Tapping head with blade shut-off  
DN32  
Ductile iron



**Series 107/31**  
90° push-in fitting for PE pipes  
Ø 32-63 mm  
DN32  
Ductile iron

- Options:
- straight push-in fitting for PE pipes
  - 45° push-in fitting
  - Supa Lock™ socket end



**Series 107/36**  
Fitting with PE pipe end  
Ø 32-40 mm  
DN32  
Ductile iron



**Series 106/01**  
Fitting with PRK coupling for PE pipes  
Ø 32-40 mm  
DN32  
Ductile iron

- Options:
- double spigot fitting
  - sensor fitting



**Series 106/01**  
Fitting with screw coupling for PE pipes  
Ø 32-50 mm  
DN32  
Brass

- Options:
- PRK coupling
  - sensor fitting



**Series 106/02**  
Threaded connector for connection to drilling machines  
1" - 2"  
DN32  
Brass

- Options:
- ductile iron
  - threaded transition connector



**Series 109**  
Spacer for flanged connections  
DN80-400  
DN32  
Ductile iron

- Options:
- 3-way socket fitting
  - socket/tyton fittings
  - blind flange

# SERVICE CONNECTION VALVES



**Series 03/00**  
Service connection valve with internal BSP thread  
DN25-50  
PN16  
Ductile iron

- Options:
- internal enamel



**Series 03/30**  
Service connection valve with tensile socket ends for PE pipes  
DN20-50  
PN16  
Ductile iron

- Option:
- duplex stem



**Series 03/40**  
Service connection valve for side tapping with internal thread /external thread  
DN25-50  
PN16  
Ductile iron



**Series 36/5X**  
Premium 100 service connection valve with PE ends  
DN25-50  
Ductile iron  
External PUR coating



**Series 03/65**  
Service connection valve with tensile screw couplings for PE pipes  
DN25-50  
PN16  
Ductile iron



**Series 03/85**  
Service connection valve with tensile screw coupling for PE pipes / external thread  
DN25-32  
PN16  
Ductile iron



**Series 36/8X**  
Service connection valve with PE ends  
DN25-50  
PE100/PN10  
Ductile iron

- Options:
- PE100/PN16
  - duplex stem



**Series 03/90**  
Service connection valve with PRK couplings for PE pipes  
DN20-50  
PN16  
Ductile iron

- Options:
- internal enamel



**Series 16/01**  
Service connection valve with PRK coupling/ external thread  
DN25-50  
PN16  
POM (Polyoxymethylene)



**Series 16/29**  
Service connection valve with tensile socket end/ external thread  
DN25-50  
PN16  
POM (Polyoxymethylene)



**Series 16/50**  
Service connection valve with tensile socket ends for PE pipes  
DN25-50  
PN16  
POM (Polyoxymethylene)

- Options:
- T-type bonnet
  - duplex stem



**Series 16/59**  
Service connection valve with Pentomech™ couplings  
DN25-50  
PN16  
POM (Polyoxymethylene)

- Option:
- duplex stem

# SERVICE CONNECTION VALVES



**Series 16/80**  
Service connection valve  
with PE ends  
DN25-50  
PE100/PN16  
POM (Polyoxymethylene)

- Options:
- T-type bonnet
  - long PE end
  - duplex stem



**Series 16/90**  
Service connection valve  
with PRK couplings  
DN25-50  
PN16  
POM  
(Polyoxymethylene)

- Options:
- T-type bonnet
  - duplex stem



**Series 16/05**  
Service connection valve  
with tensile screw  
couplings for PE pipes  
DN25-50  
PN16  
Brass

- Options:
- T-type bonnet



**Series 16/25**  
Service connection valve  
with PRK couplings for  
PE pipes  
DN25-50  
PN16  
Brass

- Options:
- T-type bonnet



**Series 11/00**  
Service connection angle  
valve with external thread  
on inlet and internal  
thread on outlet  
DN25-50  
PN16  
Ductile iron



**Series 11/30**  
Service connection angle  
valve with external thread  
on inlet and tensile socket  
end for PE pipes on outlet  
DN25-50  
PN16  
Ductile iron

# TAPPING SADDLES



**Series 10/00**  
Tapping saddle  
for uPVC and PE pipes  
DN50-300  
Ductile iron  
Lower part in stainless  
steel from DN250



**Series 10/14**  
Tapping saddle  
for cast iron, ductile iron  
and steel pipes  
DN50-300  
Ductile iron



**Series 730/2**  
Universal tapping saddle  
for ductile iron, steel and  
other metal pipes  
DN50-300  
Ductile iron/steel



**Series 730**  
Universal tapping saddle  
with blade shut-off  
for ductile iron, steel and  
other metal pipes  
DN50-300  
Ductile iron/steel

- Options:
- without blade shut-off



**Series 727/10**  
Tapping saddle  
for underpressure drilling  
For PE and PVC pipes  
DN80-200



**Series 727/09**  
Tapping saddle SWIC  
for underpressure drilling  
With integrated cutter  
For PE and PVC pipes  
DN50-200



**Series 727/19**  
Tapping saddle SWIC  
for underpressure drilling  
With integrated cutter  
For PVC pipes  
DN80-150



**Series 727/08**  
Tapping saddle SWIC  
for underpressure drilling  
With integrated cutter  
For steel pipes  
DN80-300



**Series 6731**  
Flanged universal tapping  
saddle with blade shut-  
off for iron, steel, PE and  
PVC pipes  
Ductile iron

- Options:
- slim type

# VALVE ACCESSORIES



**Series 04/02**  
Extension spindle for gate valves  
Fixed length  
DN40-400



**Series 04/04**  
Extension spindle for gate valves  
Telescopic  
DN40-600

- Options:
- with break zone



**Series 04/05**  
Extension spindle for service connection valves  
Fixed length  
DN25-50



**Series 04/07**  
Extension spindle for service connection valves  
Telescopic  
DN25-50



**Series 756/7**  
Extension spindle for double eccentric butterfly valves  
Telescopic  
DN200-1200



**Series 04/15**  
T-key for gate valves  
DN40-400



**Series 04/08/55**  
Stem caps for gate valves and service connection valves  
DN25-600



**Series 08**  
Handwheel for gate valves  
DN50-600  
CTC  
Grey cast iron

- Options:
- CTO



**Series 756/9**  
Handwheel for double eccentric butterfly valves  
DN200-600  
Grey cast iron

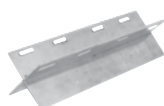

**Series 36/15**  
Valve foundation for gate valves with PE ends  
DN25-100  
Steel



**Series 756/5**  
Adaptor for connecting gear side to extension rod, wall post indicator or post indicator  
DN200-1200  
Ductile iron



**Series 910**  
Y-strainer  
DN50-300  
Ductile iron

# SURFACE BOXES



## Series 04/10

Fixed surface box  
Grey cast iron with blue epoxy

Distance ring/square for fixed surface box

Options:

- floating



## Series 04/12

Universal surface box  
Reversible design  
Ductile iron with blue epoxy



## Series 04/43

Fixed surface box  
Body of PE  
Lid of cast iron



## Series 04/007

Floating surface box for telescopic extension spindle  
Body of PE  
Flange/lid of ductile iron

Options:

- round – black epoxy
- round – blue epoxy
- square – black epoxy
- square – blue epoxy



## Series 04/008

Floating surface box for telescopic extension spindle  
Ductile iron with black epoxy

Options:

- round or square surface plate
- round or square lid



## Series 04/088

Double surface box  
Round and square lid with "V" inscription  
Ductile iron with black epoxy



## Series 80/30

Surface box "Classic" according to DIN 4055 for underground hydrants  
Fixed height  
PA+ body

Options:

- oval top
- rectangular top
- cast iron lid
- synthetic lid



## Series 80/30

Surface box "Classic" according to DIN 4055 for underground hydrants  
Height adjustable  
PA+ body  
Cast iron lid

Options:

- reinforced rim



## Series 80/30

Surface box "Futura" for underground hydrants  
Fixed height  
PA+ body

Options:

- oval top
- rectangular top
- cast iron lid
- synthetic lid



## Series 80/31

Surface box "Classic" according to DIN 4056 for distribution valves  
Fixed height  
PA+ body

Options:

- round top
- square top
- cast iron lid
- synthetic lid



## Series 80/31

Surface box "Classic" according to DIN 4056V for distribution valves  
Height adjustable  
PA+ body  
Cast iron lid

Options:

- reinforced rim



## Series 80/31

Surface box "Futura" for distribution valves  
Fixed height  
PA+ body

Options:

- round top
- square top
- cast iron lid
- synthetic lid

# SURFACE BOXES AND ACCESSORIES



**Series 80/32**  
Surface box according to DIN 4057 for service connection valves  
Fixed height  
PA+ body

- Options:
- round top
  - square top
  - cast iron lid
  - synthetic lid



**Series 80/32**  
Surface box according to DIN 4057 for service connection valves  
Height adjustable  
PA+ body  
Cast iron lid

- Options:
- reinforced rim
  - square top
  - hexagonal top



**Series 80/32**  
Surface box 4057 "Futura" for service connection valves  
Fixed height  
PA+ body

- Options:
- round top
  - square top
  - cast iron lid
  - synthetic lid
  - hexagonal top



**Series 80/21**  
Surface box "Logger" for service connection and distribution valves  
Fixed height  
Square top  
HDPE body  
Cast iron lid  
PA inscription plates



**Series 80/22**  
Surface box Multi Purpose for service connection valves  
Round top  
PA+ body

- Options:
- fixed height
  - height adjustable
  - cast iron lid
  - synthetic lid
  - inscription plate



**Series 80/41**  
Surface box PURBRA for underground hydrants  
Fixed height rectangular top  
HDPE body  
Cast iron lid  
PA inscription plate



**Series 80/40**  
Surface box PERA for distribution valves  
Fixed height square top  
HDPE body  
Cast iron lid  
PA inscription plate



**Series 80/42**  
Surface box PURDIE for service connection valves  
Fixed height square top  
HDPE body  
Cast iron lid  
PA inscription plate



**Series 80/46**  
Support tile for surface boxes for gate valves and service connection valves  
HDPE

- Options:
- large spindle fixation
  - small spindle fixation
  - spindle interface



**Series 80/46**  
Support tile for surface boxes for underground hydrants  
HDPE



**Series 80/46**  
Top frame for surface boxes  
HDPE

- Suitable in combination with various surface boxes:
- for hydrants
  - for distribution valves
  - for service connection valves

# SUPA MAXI™, SUPA PLUS™ AND SUPA® COUPLINGS, ADAPTORS AND VALVES



**Series 636**  
Supa Maxi™ gate valve  
Universal and tensile  
coupling ends for all pipes  
Ductile iron  
DN80-300  
PN16

Options:  
• Supa Maxi™/PE end



**Series 631**  
Supa Maxi™ straight  
coupling  
Universal and tensile  
for all pipes  
Ductile iron  
DN50-600  
PN16



**Series 632**  
Supa Maxi™ step  
coupling  
Universal and tensile  
for all pipes  
Ductile iron  
DN50-300  
PN16



**Series 633**  
Supa Maxi™ flange  
adaptor  
Universal and tensile  
for all pipes  
Universal drilling  
Ductile iron  
DN40-600  
PN10/16



**Series 634**  
Supa Maxi™ end cap  
Universal and tensile  
for all pipes  
Ductile iron  
DN50-400  
PN16



**Series 635**  
Supa Maxi™ transition  
coupling with PN10 or  
PN16 pipe end  
Universal and tensile  
for all pipes  
Ductile iron  
DN50-300  
PN10/16



**Series 01/70**  
Supa Plus™ gate valve  
Tensile coupling ends for  
PE and uPVC pipes  
Ductile iron  
DN40-300  
PN16

Options:  
• duplex stem



**Series 621/10**  
Supa Plus™  
straight coupling  
Tensile for PE and uPVC  
pipes  
Ductile iron  
DN32-300  
PN16



**Series 623/10**  
Supa Plus™  
flange adaptor  
Tensile for PE and uPVC  
pipes  
Universal drilling  
Ductile iron  
DN40-300  
PN10/16



**Series 624/10**  
Supa Plus™ end cap  
Tensile for PE and uPVC  
pipes  
Ductile iron  
DN40-300  
PN16



**Series 601**  
Supa® straight coupling  
universal for uPVC, AC,  
steel, cast iron and ductile  
iron pipes  
Ductile iron  
DN40-400  
PN16

Options:  
• Step coupling



**Series 603**  
Supa® flange adaptor  
universal for uPVC, AC, steel,  
cast iron and ductile iron  
pipes  
Universal drilling  
Ductile iron  
DN40-400  
PN10/16



# COMBI-FLANGES, FABRICATED COUPLINGS & ADAPTORS AND DISMANTLING JOINTS



**Series 05**  
Combi-flange for ductile iron pipes  
Non-tensile  
Ductile iron  
DN50-300  
PN10/16

Options:  
• for PVC pipes



**Series 05**  
Combi-flange for PE and PVC pipes  
Tensile  
Ductile iron  
DN50-300  
PN10/16

Options:  
• for ductile iron pipes



**Series 05**  
Combi-flange for uPVC, steel or ductile iron pipes  
Non-tensile  
Ductile iron  
DN400-600 (uPVC and ductile)  
DN50-300 (steel)  
PN10/16



**Series 05**  
Combi-flange sealing for uPVC, steel or ductile iron pipes  
Non-tensile  
SBR rubber  
DN400-600 (uPVC and ductile)  
DN50-300 (steel)



**Series 05**  
Support bush for PE pipes  
Suitable for Supa Maxi™, Supa Plus™ and combi-flanges  
Stainless steel  
DN50-600  
PN6.3/10/16



**Series 745/01**  
Repico® grip coupling  
Universal and tensile for all metal pipes  
NBR or EPDM sealing  
DN15-400  
Stainless steel AISI 316

Options:  
• for medium pressure up to DN200  
• for PE/PVC pipes



**Series 745/20**  
Repico® slip coupling  
Universal and non-tensile for all pipes  
NBR or EPDM sealing  
DN15-600  
Stainless steel AISI 316

Options:  
• 2 locks up to DN1000



**Series 258**  
Fabricated dedicated straight coupling for AC, steel, cast iron or ductile iron pipes  
Steel  
DN350-2000  
PN8 to 25

Options:  
• step coupling  
• flange adaptor



**Series 265/30**  
Fabricated dismantling joint for all pipe materials  
Steel  
DN300-1200  
PN10/16/25

Options:  
• With centre flange

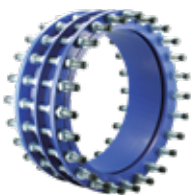

**Series 873**  
Dismantling joint for all pipe materials  
With centre flange  
DN40-2600  
PN10/16/25  
Ductile iron



**Series 8004**  
Fabricated universal flange adaptor  
Steel  
DN400-2000  
PN16

Options:  
• straight coupling  
• stainless steel



**Series 8005**  
Expansion joint  
For all pipe materials  
Steel  
DN80-1000  
PN10/16

# ENCAPSULATION COLLARS, REPAIR CLAMPS AND FITTINGS



**Series 8001**  
Hydro Stop universal  
socket encapsulation  
collar  
Steel  
EPDM rubber

Options:  
• Pipe encapsulation  
collar



**Series 8002**  
Hydro Fast dedicated  
socket encapsulation  
collar  
Steel  
EPDM rubber

Options:  
• Pipe encapsulation  
collar



**Series 8003**  
Hydro Smart dedicated  
socket encapsulation  
collar  
Steel  
EPDM rubber



**Series 748/01**  
Repair clamp  
Single band  
Stainless steel AISI 304  
or AISI 316  
NBR or EPDM rubber

Options:  
• handgrip



**Series 748/02**  
Repair clamp  
Double band  
Stainless steel AISI 304  
or AISI 316  
NBR or EPDM rubber

Options:  
• handgrip



**Series 748/03**  
Repair clamp  
Triple band  
Stainless steel AISI 304  
or AISI 316  
NBR or EPDM rubber



**Series 712**  
Flanged bend  
Ductile iron

Options:  
• various types



**Series 712**  
Flanged cross  
Ductile iron

Options:  
• various types



**Series 712**  
Flanged reducer  
Ductile iron

Options:  
• various lengths



**Series 712**  
Reducer flange  
Ductile iron



**Series 712**  
Blind flange  
Ductile iron

Options:  
• various types



**Series 712**  
Duckfoot bend  
Ductile iron

# EXPECT SUSTAINABILITY



## We contribute actively to the UN SDGs

Our solutions contribute to the UN sustainable development goals by ensuring clean water and sanitation, by reducing water waste, electricity consumption and CO2 emissions, and by turning wastewater into affordable and clean energy. Our valve design is not only optimised to ensure long durability and 100% tightness; it also offers low operating torque, allowing for the use of cost-efficient electrical actuators.

AVK has entered into partnerships with other leading Danish companies aimed at sharing knowledge within water technology and at offering joint solutions for a more sustainable world. Furthermore, to help implement the already known and well-proven technologies, we have founded and host a summer school which runs under the name "Advanced Water Cycle Management Course". With the latest knowledge at hand and a holistic approach to the journey of water through society, we focus on obtaining the most efficient supply and treatment processes.

## Sustainable production

At the AVK Advanced Castings foundry, supplying the AVK Group with castings for valves and hydrants and other metal castings, we use the innovative lost foam method, and this method allows for an improvement in performance, reducing energy consumption and the amount of particle emissions into the atmosphere. In our castings, we use recycled

steel scrap as the principal component – up to 85-90% of the total melt.

The AVK Group has strict requirements and standards for energy and water consumption its production companies must meet. Consequently, all companies make great efforts to reduce consumption wherever they can.

## Global responsibility

AVK is a global company operating worldwide and must as such take different circumstances and conditions in different countries into account and the consequent risks. In all countries where AVK is present, it is fundamental to act responsibly towards employees, environment and the surrounding society.

The AVK Group keeps a close watch on all business units and ensures through regular visits that all AVK companies comply with the defined human rights principles and criteria. Whatever country or location, we focus on the health and safety of our employees. We carefully monitor the number of work-related accidents and work proactively on preventive measures. The result of this is a steady decline in the number of accidents. We also ensure maintenance, inspection and development of working conditions, equipment and tools that are necessary to complete a given business process.

The AVK Group has agreed to adhere to standards that our suppliers must adhere to as well in order to become a certified supplier of the Group. Sustainability is vital for us throughout the entire supply chain. Therefore, we only cooperate with partners with high ethical standards, who are strongly committed to comply with international legislation in the field of labour.

**PT. AVK Fusion Indonesia**

Taman Tekno Blok F1/F-CDE  
BSD City, Serpong,  
Tangerang Selatan,  
Banten 15314

Tel.: +62-21-75682627  
Fax: +62-21-75682628  
<https://www.avkfusion.co.id>  
[customercare@avkfusion.co.id](mailto:customercare@avkfusion.co.id)

Copyright©AVK Fusion Indonesia 2023

Expect... **AVR**

